

## 5555 Back Pressure Valve, Double Seated (Balanced)

### Application

This unique valve, with its simple and near-balanced double-seated design, along with its history of trouble free operation, has contributed materially to its wide acceptance in the oil industry. Primary application is to hold back pressure on separators, treaters, Lact units, and other accumulators when upstream pressure is required to be kept at a preset range. However, this valve may also be used as a differential valve by utilizing secondary signal pressure, along with spring force on top of the diaphragm, to oppose flow pressure applied to the bottom of the diaphragm.

### Features

- Simple Design
- Self-Contained: There are no pilots or small orifices to plug or freeze.
- Easy Access: All internal parts can be removed without taking valve out of line.
- Available in 2" Threaded: 2", 3", 4" Flanged
- Molded Buna-N or Viton® Plugs for Corrosion Resistance & Tight Shut-Off
- Multiple Spring Ranges: 0-30 lb to 20-150 lb

### Specifications

Size	2" Threaded	2", 3", 4" Flanged
Working Pressure	Dictated by Spring Range	
Spring Range	0-30 lb to 20-150 lb	
Temperature	-50°F to +250°F Standard (other materials available)	
Size Topworks	#10 or #20	
(C <sub>v</sub> ) Flow Coefficient	2" = 40	3" = 70    4" = 110

### Material

Body	Ductile Iron	
Topworks	#20 Press Steel	#10 WCB
Diaphragm	Molded Nylon Reinforced Buna-N (Viton® Available)	
Stem	303 SS	
Packing	Cotton Reinforced Nitrile	
Trim	Buna-N or Viton® Molded Plug, Integral Seat	



### Dimensional Data

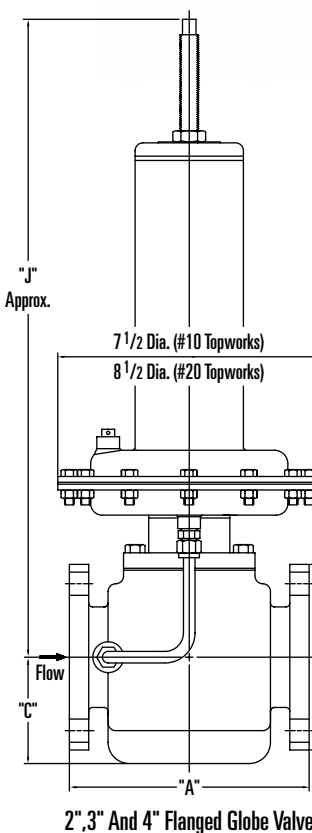

### General Dimensions

Size	"A"	"C"	"D"	"J"
2"	7 3/4"	3 7/16"	6"	21"
3"	11"	4 1/4"	7 1/2"	22"
4"	12 3/4"	5"	9"	23"

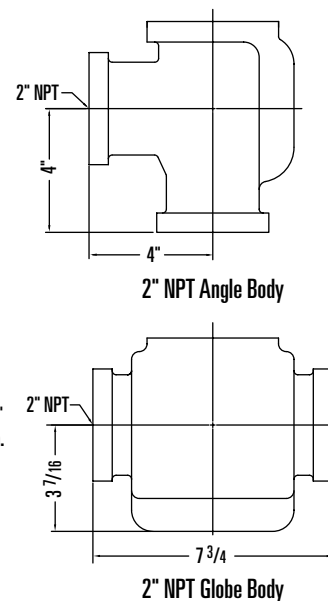

# 5555 Back Pressure Valve, Double Seated (Balanced)

## Parts List Series 5555 w/#20 Topworks

Item	Description	Qty.	Part No.		
			2"	3"	4"
1	BODY, 2"NPT ANGLE, DUCTILE IRON	1	05010-1214		
	BODY, 2"NPT GLOBE, DUCTILE IRON	1	05012-3614		
	BODY, FLANGED GLOBE, DUCT. IRON	1	05011-7639	05011-8355	05011-8371
2	DIA. SUPPORT, STEEL	1	05011-5195		
	DIA. SUPPORT, DUCTILE IRON	1		05013-0455	05013-0463
3*	GASKET, MOLDED BUNA-N	1	05011-0816	05011-0857	05011-0840
4*	BOTTOM PLUG, MOLDED BUNA-N	1	05010-1252	05010-1369	05010-1377
5*	TOP PLUG, MOLDED BUNA-N	1	05010-1260	05011-2663	05011-2655
6	STEM, ASTM A-582 TY.303	1	05010-1435	05010-1419	05010-1427
7	SPACER, ASTM A-582 TY.303	1	05011-3455	05010-1443	05010-1468
8	TRAVEL STOP, ASTM A-582 TY.303	1	05010-6798	05010-6277	05010-6285
9	LINKAGE, ASTM A-582 TY.303	1	05010-1351	05010-1864	
10	FLAT HD. SCREW, STAINLESS STEEL	4	05000-1759	05000-2278	
11	HINGE PIN, STAINLESS STEEL	1	05010-2037	05010-2029	
12	WASHER, ASTM A-582 TY.303	1	05010-1492	05010-1450	
13	FLEX-LOC NUT, STAINLESS STEEL	1	05000-2062	05000-2096	
14	LOWER CASE, ASTM A-569	1	06500-1257	06500-0572	
15	COTTER PIN, MONEL	1	06000-0239	06000-0247	
16	CAP SCREW, ASTM A-307 GR.B	4	05000-1841	05000-2013	
17*	GASKET, MOLDED BUNA-N	1	05010-3662	05010-4579	
18	SPACER, DELRIN	1	05010-8000	05010-4322	
19*	PACKING, COTTON REIN. NITRILE	3	06000-0387		
	PACKING, COTTON REIN. NITRILE	2		06000-0387	
20	LOCK WASHER, STEEL	1		06000-0403	
21	NY-LOC NUT, ASTM A-307 GR.B	1		05000-2997	
22	DIAPH. PLATE, ASTM A-569	2		05010-1922	
23*	DIAPH. 0-30#, NYLON RENF. NITRILE	1		06000-0056	
	DIAPH. 30-100#, NYLON RENF. NITRILE	1		06000-0064	
24	UPPER GUIDE, ASTM A-108GR.1213	1		05010-1906	
	UPPER GUIDE 50-100#, ASTM A-108GR.1213	1		05010-5071	
25	LOWER GUIDE, ASTM A-366	1		05010-1914	
	LOWER GUIDE 50-100#, ASTM A-366	1		05010-5089	
26	SPRING 0-30#, ASTM A-401	1		05010-1344	
	SPRING 10-80#, ASTM A-401	1		05010-6293	
27	ADJ. SCREW, ASTM A-307 GR.B	1		05010-7820	
28	JAM NUT, ASTM A-307 GR.B	1		05000-2070	
29	UPPER CASE, ASTM A-569	1		06500-1042	
30	CAP SCREW, ASTM A-307 GR.B	12		05000-1742	
31	HEX NUT, ASTM A-307 GR.B	12		05000-1726	
32	BREATHER, HPE	1		05011-1640	
33	SPRING, INNER, ASTM A-401	1		05010-5055	
34*	THREAD SEAL, STEEL/BUNA-N	1		06000-0395	
35*	PACKING, FLAT, COTTON REIN. NITRILE	1		06000-0528	
36	PACKING ADJ., ASTM B-16	1		05010-3639	
37	CONNECTOR, BRASS	2		06000-0429	
38	TUBING, COPPER	1		06000-0437	

\*Recommended Spare Part

## Model and Part No.

Size	Model No.	Body Material	Spring Range	C <sub>v</sub>	Wt.	Part No.
2"	220-DSA-B-N	DUCTILE IRON	0-30 lbs	40	42#	03004-0034
	220-DSA-B-N		10-80 lbs			03004-0067
	220-DSA-B-N		50-100 lbs			03004-0000
	220-DSG-B-N		0-30 lbs	40	46#	03004-0200
	220-DSG-B-N		10-80 lbs			03004-0213
	220-DSG-B-N		50-100 lbs			03004-0221
3"	320-DFG-B-N	DUCTILE IRON	0-30 lbs	70	78#	03004-0059
	320-DFG-B-N		10-80 lbs			03004-0083
	320-DFG-B-N		50-100 lbs			03004-0026
	320-DFG-B-N		0-30 lbs	110	123#	03028-0093
	320-DFG-B-N		10-80 lbs			03028-0101
	320-DFG-B-N		50-100 lbs			03028-0051
4"	420-DFG-B-N	DUCTILE IRON	0-30 lbs	110	123#	03028-0184
	420-DFG-B-N		10-80 lbs			03028-0192
	420-DFG-B-N		50-100 lbs			03028-0234

## Determining the Model Number

Example given: Model 410-DFG-B-V – Series 5555, 4" Flanged Globe Body, #10 Topworks, Viton® Plug, Back Pressure Valve.

### MODEL 410-DFG-B-V

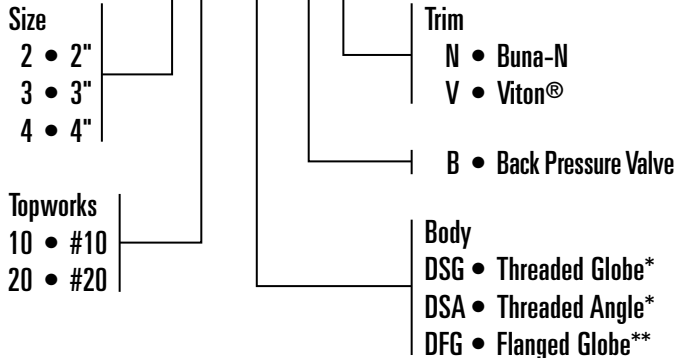

\* Available in 2" Only  
 \*\*Specify Flange Rating

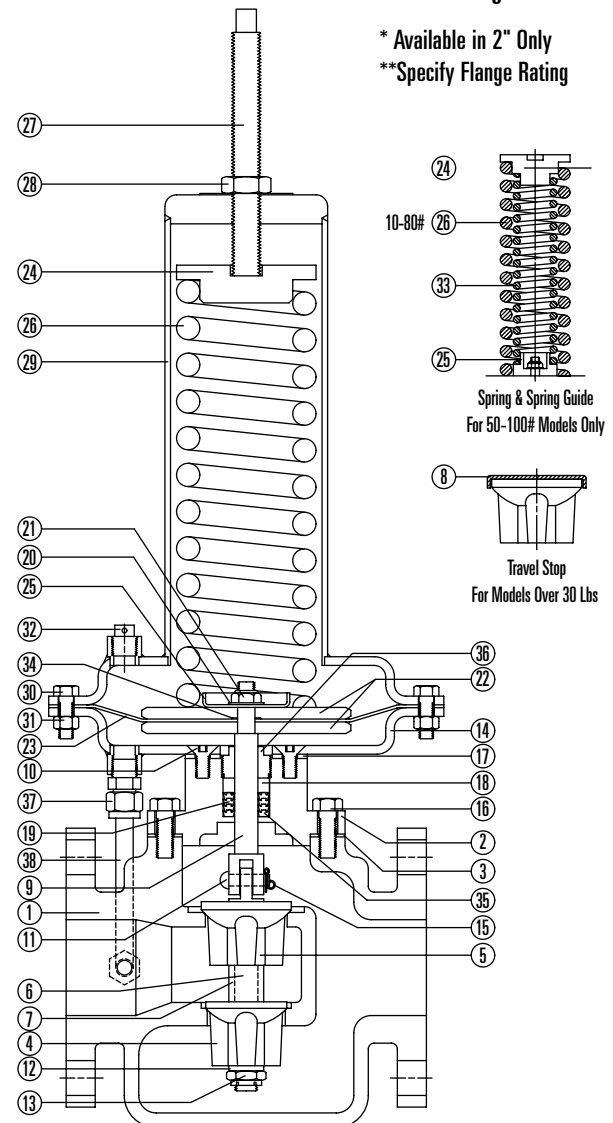

# 5555 Back Pressure Valve, Double Seated (Balanced)

## Parts List Series 5555 w/#10 Topworks

Item	Description	Qty.	Part No.		
			2"	3"	4"
1	BODY, 2"NPT ANGLE, DUCTILE IRON	1	05010-1214		
	BODY, 2"NPT GLOBE, DUCTILE IRON	1	05012-3614		
	BODY, FLANGED GLOBE, DUCT. IRON	1	05011-7639	05011-8355	05011-8371
2	DIA. SUPPORT, ASTM A-216 GR.WCB	1	05010-8596	06500-1968	06500-1976
3*	GASKET, MOLDED BUNA-N	1	05011-0816	05011-0857	05011-0840
4*	BOTTOM PLUG, MOLDED BUNA-N	1	05010-1252	05010-1369	05010-1377
5*	TOP PLUG, MOLDED BUNA-N	1	05010-1260	05011-2663	05011-2655
6	STEM, ASTM A-582 TY.303	1	05010-1435	05010-1419	05010-1427
7	SPACER, ASTM A-582 TY.303	1	05011-3455	05010-1443	05010-1468
8	TRAVEL STOP, ASTM A-582 TY.303	1	05010-6798	05010-6277	05010-6285
9	LINKAGE, ASTM A-582 TY.303	1	05010-8794	05010-1864	
10	CAP SCREW, ASTM A-307 GR.B	4	05000-1841	05000-2013	
11	HINGE PIN, STAINLESS STEEL	1	05010-2037	05010-2029	
12	WASHER, ASTM A-582 TY.303	1	05010-1492	05010-1450	
13	FLEX-LOC NUT, STAINLESS STEEL	1	05000-2062	05000-2096	
14	COTTER PIN, MONEL	1	06000-0239	06000-0247	
15*	THREAD SEAL, STEEL/BUNA-N	1		06000-0395	
16	TRU-ARC RING, STAINLESS STEEL	1		06000-0452	
17	STEM GUIDE, DELRIN	1		05010-8638	
18	SPACER, DELRIN	1		05010-8646	
19*	POLYPAK, MOLYTHANE	1		06000-0353	
20	LOCK WASHER, STEEL	1		06000-0403	
21	NY-LOC NUT, ASTM A-307 GR.B	1		05000-2997	
22	DIAPH. PLATE, ASTM A-569	2		05010-8786	
23*	DIAPHRAGM, NYLON RENF. NITRILE	1		05010-8612	
24	UPPER GUIDE, ASTM A-108GR.1213	1		05010-1906	
25	LOWER GUIDE, ASTM A-366	1		05010-1914	
26	SPRING 0-60#, ASTM A-401	1		05010-1344	
	SPRING 20-150#, ASTM A-401	1		05010-6293	
27	ADJ. SCREW, ASTM A-307 GR.B	1		05010-7820	
28	JAM NUT, ASTM A-307 GR.B	1		05000-2070	
29	UPPER CASE, ASTM A-216 GR.WCB	1		06500-0986	
30	CAP SCREW, ASTM A-307 GR.B	8		05000-1890	
31	HEX NUT, ASTM A-307 GR.B	8		05000-2104	
32	BREATHER, HPE	1		05011-1640	
33	PIPE PLUG, STEEL	1		06000-0478	
34	TUBING, COPPER	1		06000-0437	
35	ELBOW CONN., BRASS	1		06000-0445	
36	CONNECTOR, BRASS	1		06000-0429	
37	SEAL WASHER, STEEL PLATED	1		06000-0460	

\*Recommended Spare Part

### Model and Part No.

Size	Model No.	Body Material	Spring Range	C <sub>v</sub>	Wt.	Part No.
2"	210-DSA-B-N	DUCTILE IRON	0-60 lbs	40	48#	03005-0070
	210-DSA-B-N		20-150 lbs			03005-0080
	210-DSG-B-N		0-60 lbs	40	52#	03005-0041
	210-DSG-B-N		20-150 lbs			03005-0058
	210-DFG-B-N		0-60 lbs	40	55#	03005-0009
	210-DFG-B-N		20-150 lbs			03005-0017
3"	310-DFG-B-N	DUCTILE IRON	0-60 lbs	70	80#	03033-0039
	310-DFG-B-N		20-150 lbs			03033-0047
4"	410-DFG-B-N	DUCTILE IRON	0-60 lbs	110	120#	03034-0038
	410-DFG-B-N		20-150 lbs			03034-0046

